

ecostore
2 Door Digital Refrigerator, 1430 lt
(0/+6) with wheels - R290

ITEM # _____

MODEL # _____

NAME # _____

SIS # _____

AIA # _____

725380 (RE471FLR)

 2-door Refrigerator 1430lt,
 with wheels, 0/+6°C, digital,
 AISI 304, R290

Short Form Specification

Item No.

Two full doors refrigerator with internal and external structure in 304 AISI stainless steel; external back panel in galvanized steel and bottom panel in anti-corrosive material. Digital control with cabinet temperature display and setting and manual activation of defrost cycle. Fully compliant HACCP digital controls include visible alarms. Optimized back to front forced air flow provides even temperature distribution and fast cooling in any conditions. Fitted with 75 mm-thick cyclopentane insulating foam. Door features lock and door microswitch to switch off the fan when the door is opened. Hidden evaporator to guarantee higher storage capacity and less corrosion problems. Built-in refrigeration unit; ventilated operation; automatic defrost and evaporation of defrost water. Operating temperature: 0/+6 °C. CFC and HCFC free. R290 gas in refrigeration circuit. Integrated RS485 port to facilitate connection to a remote computer and integrated HACCP systems. Mounted on wheels and equipped with Schuko plug.

Main Features

- Automatic defrost.
- Large storage area suitable to contain 2/1 GN grids or shelves on anti-tilt runners.
- Cabinet fitted with up to 75 mm thickness of cyclopentane insulation for best insulating performance with 100% environmental protection (thermal conductivity: 0,020 W/m* K).
- Hidden evaporator thus guaranteeing higher storage capacity and less corrosion problems.
- Internal structure with numerous charging positions available to host grids, ensuring higher net capacity and a greater storage space.
- 60 mm-thick insulation covering the evaporator can be easily removed with a single operation.
- Optimized back to front forced air flow provide even temperature distribution and fast cooling in any conditions.
- Operating temperatures can be adjusted from 0 to +6 °C to suit both meat and dairy storage requirements.
- Equipped with single phase electrical cable and Schuko plug for easy and fast installation.
- Tropicalized unit.

Construction

- Lockable door.
- The rounded internal corners, the easily removable runners and grids allow for ease of cleaning and high hygiene standards.
- Constructed from the highest quality AISI 304 Stainless steel.
- Easy access to the main components for maintenance.
- Stainless steel runners and supports easily disassembled.
- Anti-corrosion bottom material avoids any damage that may be caused to the cabinet by aggressive detergents employed to clean the floors.
- Doors are self-closing and can be fully opened up to 180°.
- AISI 430 stainless steel internal structure and external panels.
- Mounted on wheels.

Sustainability



- Automatic evaporation of the defrosting water by hot gas on the top for energy saving.
- Door switch stops the fan when door is opened to avoid cold air exiting the cell, thus saving energy.

APPROVAL: _____

- CFC and HCFC free, highly ecological refrigerant type: R290 (ecological gas in foam: cyclopentane). Hydrocarbon refrigerant gas R290 for the lowest environmental impact (GWP=3), to reduce green house and ozone depletion effects.
- Removable triple-chamber balloon magnetic gasket to improve insulation and reduce energy consumption and ease of cleaning.
- Cleaning-free condenser: the structure of the wire frame condenser prevents dust and grease accumulation thus avoiding periodical cleaning operations and reducing energy consumption.
- S05 - MULTIPURPOSE DEGREASER; PNC 0S3257
 6PCS X 750ML; ADR&IMDG Limited Quantity

Included Accessories

- 6 of 2/1GN grey rilsan grid with 2 runners PNC 881020
- 1 of Kit of 4 small swivelling wheels, 2 with brake, diam 50 mm, not for remote models PNC 881035

Optional Accessories

- 2 stainless steel runners for refrigerated cabinets - (Marine) PNC 880242
- Set of 8 GN1/1 PVC containers for fish PNC 880243
- Spacer for 670 lt and 1430 lt refrigerated cabinets PNC 880248
- Kit remote alarm PNC 880570
- Ethernet connectivity kit IJF for Refrigeration PNC 880685
- 1/1GN plastic container with false bottom PNC 880705
- Kit of 10 pairs of runners and 4 tray supports to fit pastry trays (400x600mm) PNC 881003
- 2/1GN grey rilsan grid PNC 881004
- 2/1GN aisi 304 stainless steel grid PNC 881016
- 2/1GN 304 AISI stainless steel grid with 2 runners PNC 881018
- Meat rail for 670/1430lt refrigerators with 4 hooks PNC 881019
- 2/1GN grey rilsan grid with 2 runners PNC 881020
- Set of 2 stainless steel runners for 670/1430lt refrigerators and freezers PNC 881021
- 2/1GN perforated shelf PNC 881042
- 1/1GN rilsan steel wire basket h=150mm PNC 881043
- 5 swivelling wheels (2 with brake), diam 125mm, for 1430 lt refrigerators, NOT for remote models PNC 881294
- IoT module for refrigerated cabinets and counters PNC 881298
- POE switch PNC 922432

Recommended Detergents

- S01 STAINLESS STEEL SURFACE POLISHER; 6 BOTTLES X 750ML C/T PNC 0S2881

Front

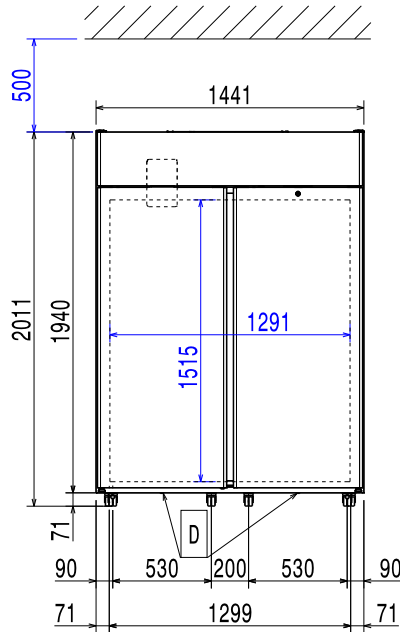

Side

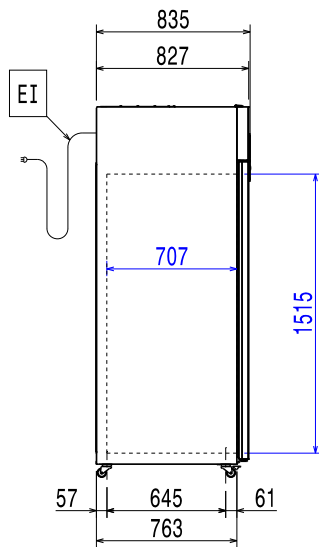

EI = Electrical inlet (power)

Top

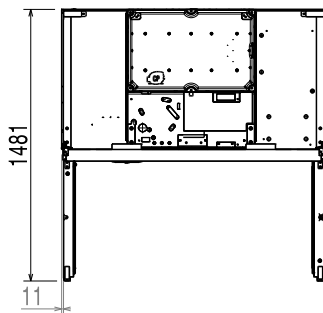
Electric

Supply voltage: 220-240 V/1 ph/50 Hz
 Electrical power, max: 0.3 kW

Capacity:

Number and type of grids (included): 6 - GN 2/1

Key Information:

Net Volume: 1135 lt
 Door hinges:
 External dimensions, Width: 1441 mm
 External dimensions, Depth: 835 mm
 External dimensions, Depth with Doors Open: 1480 mm
 External dimensions, Height: 2010 mm
 Number and type of doors: 1 Full
 Type of external material: 304 AISI
 Type of internal material: 304 AISI
 Internal panels material: 304 AISI
 Number of positions & pitch: 44; 30 mm
 Gross capacity: 670 lt
 Type of model (EU Regulation. 2015/1094): vertical chilled

Refrigeration Data

Control type: Digital
 Refrigeration power at evaporation temperature: -10 °C
 Operating temperature min.: 0 °C
 Operating temperature max.: 6 °C
 Compressor power: 1/5 hp
 Operating mode: Ventilated

ISO Certificates

ISO Standards: ISO 9001; ISO 14001; ISO 45001; ISO 50001

Sustainability

Refrigerant type: R290
 GWP Index: 3
 Refrigeration power: 278 W
 Refrigerant weight (unit 1): 120 g
 Energy Class (EU Reg. 2015/1094): D
 Yearly and daily energy consumption (EU Reg. 2015/1094): 1427kWh/year - 3.91kWh/24h
 Climate class (EU Reg. 2015/1094): Heavy Duty (5)
 Energy Efficiency Index-EEL (EU Reg. 2015/1094): 57,68

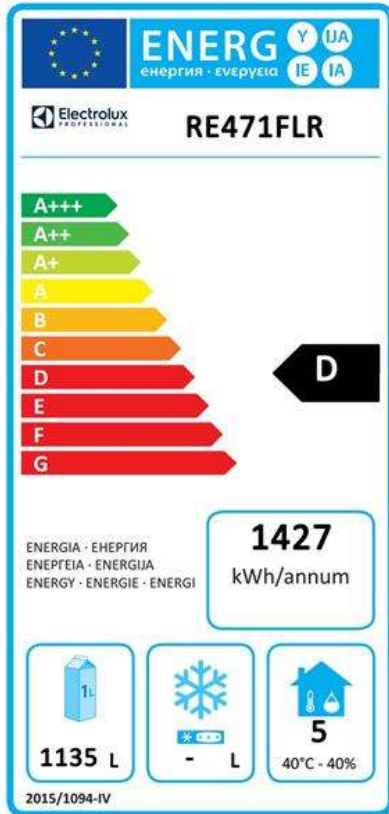

EU energy labelling from 1st July 2016

The European energy labelling scheme for professional refrigerators and freezers is based on requirements setting Minimum Energy Performance standards for commercial refrigeration cabinets sold within the EU.

These requirements are designed to drive energy efficiency and environmentally friendly approach for professionals. The European energy labelling scheme will apply to all manufacturers and importers who sell and market products within the EU and it is mandatory across Europe. Important: all products which consume energy above the minimum level will not be able to be sold within the EU from 1 July 2016.

SI 2020 No. 1528.

Important: all products which consume energy above the minimum level will not be able to be sold within the EU from 1 July 2016.

